

Features

- ✧ Built-in MCU, data sampling and processing in real time.
- ✧ Fixed temperature and rate of rise alarming modes.
- ✧ Fire LED allows 360°viewing.
- ✧ Remote indicator output available.
- ✧ Reed switch testing.
- ✧ Comply with EN54-5 standard.



Description

VG-6633 Conventional Heat Detector (the detector) is non-addressable, developed by our company. With built-in microprocessor, it works stably by being fixed with highly reliable fire judging program. When the detector checks fire signal, it can change its own current to transmit fire signal to control panel or interface module. The detector keeps illuminating fire LED to indicate fire status until resetting. NTC thermistor is adopted as sensing element for the detector.

Installation

The orientation base VG-6611 is shown in Fig. 2.

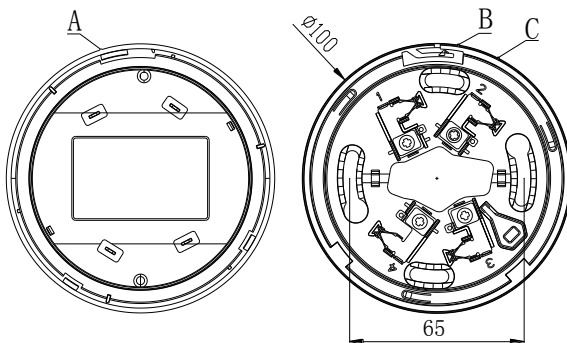

Fig. 1 Detector Bottom Fig. 2 Detector Base

There are four terminals with numbers on the base.

- 1: Detection zone positive IN
- 2: Detection zone positive OUT
- 3: Detection zone negative IN and OUT
- 2: Positive terminal of remote indicator
- 4: Negative terminal of remote indicator

Recommended Wiring:

1.0mm² or above fire cable for all terminals, laid through metal conduit or flame-proof conduit, subject to local codes.

Note: It's recommended to use cables of different colors to avoid incorrect wiring.

First fix the orientation base with two tapping screws. Then align A (Fig. 1) on the bottom of the detector to B (Fig. 2) of the base, and rotate the detector clockwise to mark C.

Mounting of the detector is shown in Fig. 3.

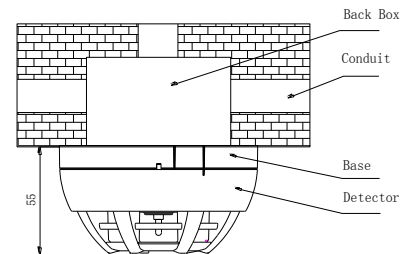

Fig. 3

Application

Warning: The alarm current depends on the current limit of the FACP. 24VDC power cannot be applied to the detector directly. Otherwise the detector may be damaged for lack of current-limit resistor.

The detector is applicable for many places such as hotels, restaurants, office buildings, teaching buildings, banks, warehouses, libraries, computer rooms and switching rooms and so on.

✧ When the detector is connected with VG-6831 conventional fire alarm control panel or the addressable zone monitor unit, if a 4.7KΩ terminal resistor is connected to the end of output loop, then VG-6611 base is used. The system composition is shown in Fig. 4.

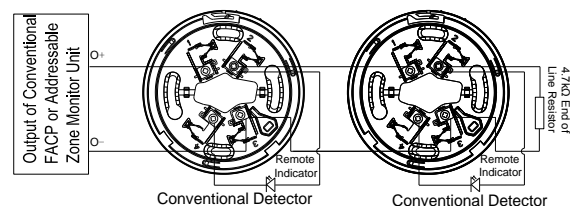

Fig. 4

◇ When multiple detectors are connected with a remote indicator, a diode 1N5819 should be connected to Terminal 4 of VG-6611 orientation base in series before going to the positive of the remote indicator. System composition is shown in Fig. 5.

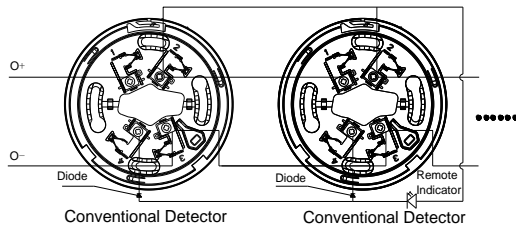

Fig. 5

Output loop of VG-6831 conventional control panel can be connected with up to 30 non-addressable field

devices. The control panel features loop checking.

When the loop is broken, the panel will send fault signal for warning.

Reed Switch Testing:

Put commission tool neat the LED on the detector for 3 to 5 seconds.

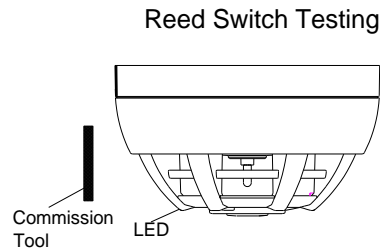

Maintenance

1. The detector should be installed just before commission and kept well before installation, taken corresponding measures for dust-proof, damp-proof and corrosion-proof.
2. Protect the metal component on the PCB against damp and improper distortion.
3. Fire simulation test should be made to the detector at least once half a year

Specification

Operating Voltage	9VDC~28VDC
Static Current	≤60μA
Alarm Current	10mA≤I≤50mA
Fire LED	Red. Flashes once every 2s~4s in normal state; Illuminates in alarm.
Remote Indicator	Directly connects with remote indicator (internal 10kΩ resistor in series output power supply voltage) Quiet in normal state, flashes in alarm.
Max. ripple voltage	2V(peak to peak value)
Alarm reset	Instant power down (2s Min, 1.0VDC Max)
Power-up Time	≤10s

Wiring	Polarized two wire
Class	A2R
Ingress Protection Rating	IP32
Ambient Temperature	-10℃~+55℃
Relative Humidity	≤95%, non condensing
Material of Enclosure	ABS
Dimensions	Diameter: 100mm Height: 43mm (without base)
Mounting Hole Spacing	65mm
Weight	About 120g

Accessories & Tools

Model	Name	Remarks
VG-6611	Base	Order separately

Limited Warranty

We will repair or replace any properly used product that fails to operate due to material or craftsman defects within the warranty period. Any failure caused by intentional damage, improper use or tamper falls outside of this warranty and we are not responsible for any such consequence. Anybody, including agents, distributors and employees, is not authorized to alter the contents of this warranty. Please contact your local distributor for products that are not within the scope of this warranty.



Company: V-GREAT GLOBAL CORPORATION

Add.: Second Floor, Capital City, Independence Avenue, P.O. Box 1008, Victoria, Mahe, Seychelles

Web: <http://www.vgreatglobal.com>

Email: tech@vgreatglobal.com